

HIGH CURRENT SWITCHING REGULATORS

- 4 A OUTPUT CURRENT
- 5.1 V TO 40 V OUTPUT VOLTAGE RANGE
- 0 TO 100 % DUTY CYCLE RANGE
- PRECISE (± 2 %) ON-CHIP REFERENCE
- SWITCHING FREQUENCY UP TO 200 KHz
- VERY HIGH EFFICIENCY (UP TO 90 %)
- VERY FEW EXTERNAL COMPONENTS
- SOFT START
- RESET OUTPUT
- EXTERNAL PROGRAMMABLE LIMITING CURRENT (L296P)
- CONTROL CIRCUIT FOR CROWBAR SCR
- INPUT FOR REMOTE INHIBIT AND SYNCHRONOUS PWM
- THERMAL SHUTDOWN

DESCRIPTION

The L296 and L296P are stepdown power switching regulators delivering 4 A at a voltage variable from 5.1 V to 40 V.

Features of the devices include soft start, remote inhibit, thermal protection, a reset output for microprocessors and a PWM comparator input for synchronization in multichip configurations.

The L296P includes external programmable limiting current.

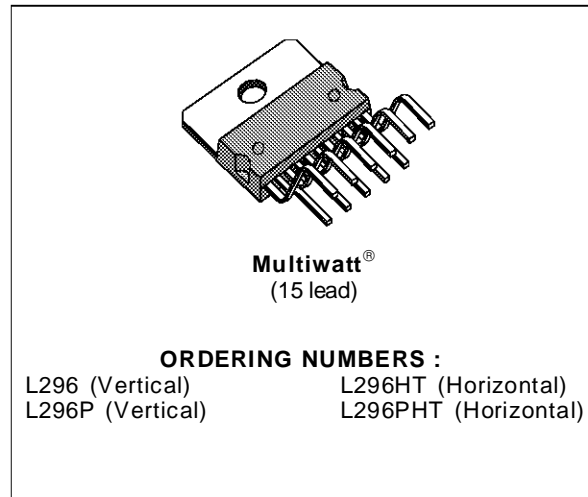

The L296 and L296P are mounted in a 15-lead Multiwatt® plastic power package and requires very few external components.

Efficient operation at switching frequencies up to 200 KHz allows a reduction in the size and cost of external filter components. A voltage sense input and SCR drive output are provided for optional crowbar overvoltage protection with an external SCR.

PIN CONNECTION (top view)

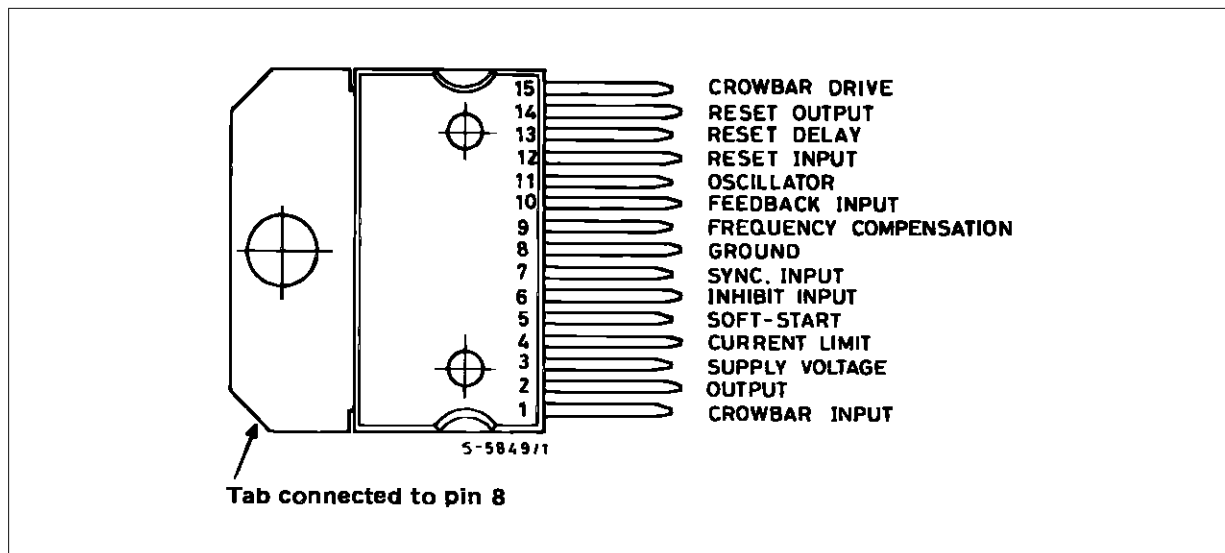

PIN FUNCTIONS

| N° | Name | Function |
|----|------------------------|--|
| 1 | CROWBAR INPUT | Voltage Sense Input for Crowbar Overvoltage Protection. Normally connected to the feedback input thus triggering the SCR when V_{out} exceeds nominal by 20 %. May also monitor the input and a voltage divider can be added to increase the threshold. Connected to ground when SCR not used. |
| 2 | OUTPUT | Regulator Output |
| 3 | SUPPLY VOLTAGE | Unregulated Voltage Input. An internal Regulator Powers the L296s Internal Logic. |
| 4 | CURRENT LIMIT | A resistor connected between this terminal and ground sets the current limiter threshold. If this terminal is left unconnected the threshold is internally set (see electrical characteristics). |
| 5 | SOFT START | Soft Start Time Constant. A capacitor is connected between this terminal and ground to define the soft start time constant. This capacitor also determines the average short circuit output current. |
| 6 | INHIBIT INPUT | TTL – Level Remote Inhibit. A logic high level on this input disables the device. |
| 7 | SYNC INPUT | Multiple L296s are synchronized by connecting the pin 7 inputs together and omitting the oscillator RC network on all but one device. |
| 8 | GROUND | Common Ground Terminal |
| 9 | FREQUENCY COMPENSATION | A series RC network connected between this terminal and ground determines the regulation loop gain characteristics. |
| 10 | FEEDBACK INPUT | The Feedback Terminal on the Regulation Loop. The output is connected directly to this terminal for 5.1V operation ; it is connected via a divider for higher voltages. |
| 11 | OSCILLATOR | A parallel RC network connected to this terminal determines the switching frequency. This pin must be connected to pin 7 input when the internal oscillator is used. |
| 12 | RESET INPUT | Input of the Reset Circuit. The threshold is roughly 5 V. It may be connected to the feedback point or via a divider to the input. |
| 13 | RESET DELAY | A capacitor connected between this terminal and ground determines the reset signal delay time. |
| 14 | RESET OUTPUT | Open collector reset signal output. This output is high when the supply is safe. |
| 15 | CROWBAR OUTPUT | SCR gate drive output of the crowbar circuit. |

BLOCK DIAGRAM

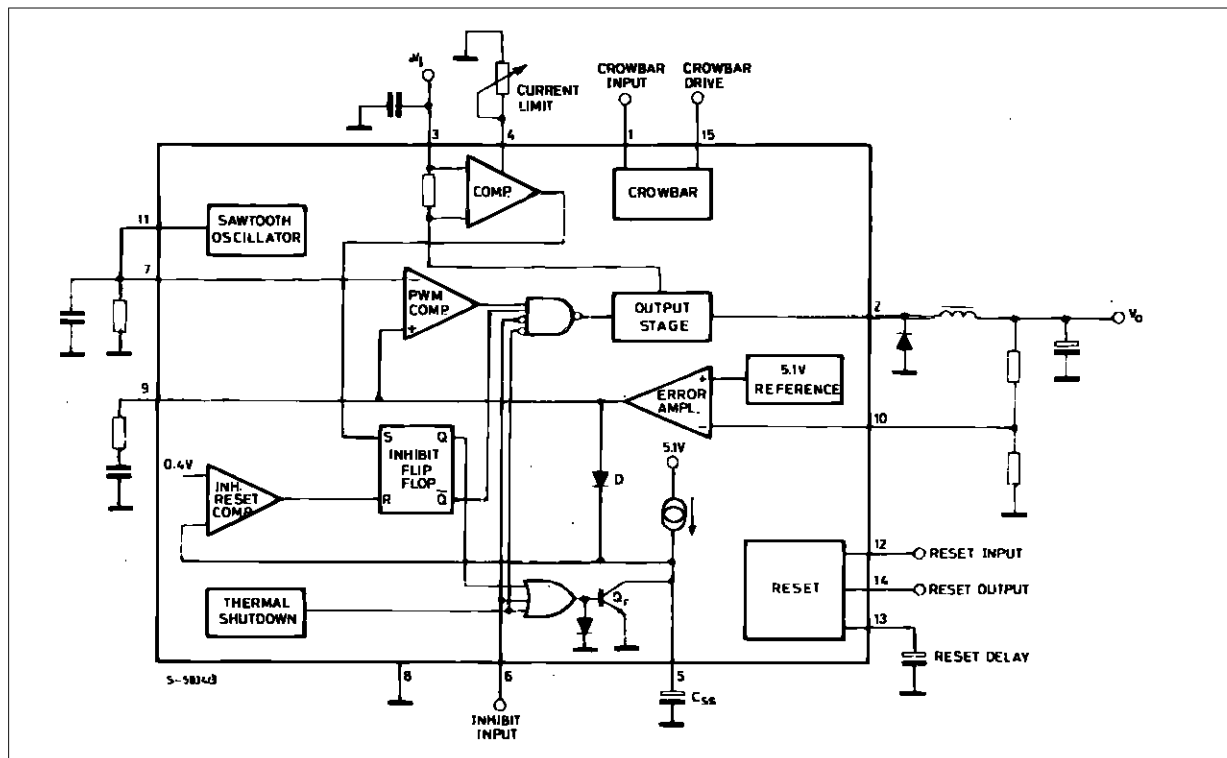

CIRCUIT OPERATION

(refer to the block diagram)

The L296 and L296P are monolithic stepdown switching regulators providing output voltages from 5.1V to 40V and delivering 4A.

The regulation loop consists of a sawtooth oscillator, error amplifier, comparator and the output stage. An error signal is produced by comparing the output voltage with a precise 5.1V on-chip reference (zener zap trimmed to $\pm 2\%$). This error signal is then compared with the sawtooth signal to generate the fixed frequency pulse width modulated pulses which drive the output stage. The gain and frequency stability of the loop can be adjusted by an external RC network connected to pin 9. Closing the loop directly gives an output voltage of 5.1V. Higher voltages are obtained by inserting a voltage divider.

Output overcurrents at switch on are prevented by the soft start function. The error amplifier output is initially clamped by the external capacitor C_{SS} and allowed to rise, linearly, as this capacitor is charged by a constant current source.

Output overload protection is provided in the form of a current limiter. The load current is sensed by an internal metal resistor connected to a comparator. When the load current exceeds a preset threshold this comparator sets a flip flop which disables the output stage and discharges the soft start capacitor. A second comparator resets the flip flop when the voltage across the soft start capacitor has fallen to

0.4V. The output stage is thus re-enabled and the output voltage rises under control of the soft start network. If the overload condition is still present the limiter will trigger again when the threshold current is reached. The average short circuit current is limited to a safe value by the dead time introduced by the soft start network.

The reset circuit generates an output signal when the supply voltage exceeds a threshold programmed by an external divider. The reset signal is generated with a delay time programmed by an external capacitor. When the supply falls below the threshold the reset output goes low immediately. The reset output is an open collector.

The scrowbar circuit senses the output voltage and the crowbar output can provide a current of 100mA to switch on an external SCR. This SCR is triggered when the output voltage exceeds the nominal by 20%. There is no internal connection between the output and crowbar sense input therefore the crowbar can monitor either the input or the output.

A TTL - level inhibit input is provided for applications such as remote on/off control. This input is activated by high logic level and disables circuit operation. After an inhibit the L296 restarts under control of the soft start network.

The thermal overload circuit disables circuit operation when the junction temperature reaches about $150\text{ }^{\circ}\text{C}$ and has hysteresis to prevent unstable conditions.

Figure 1 : Reset Output Waveforms

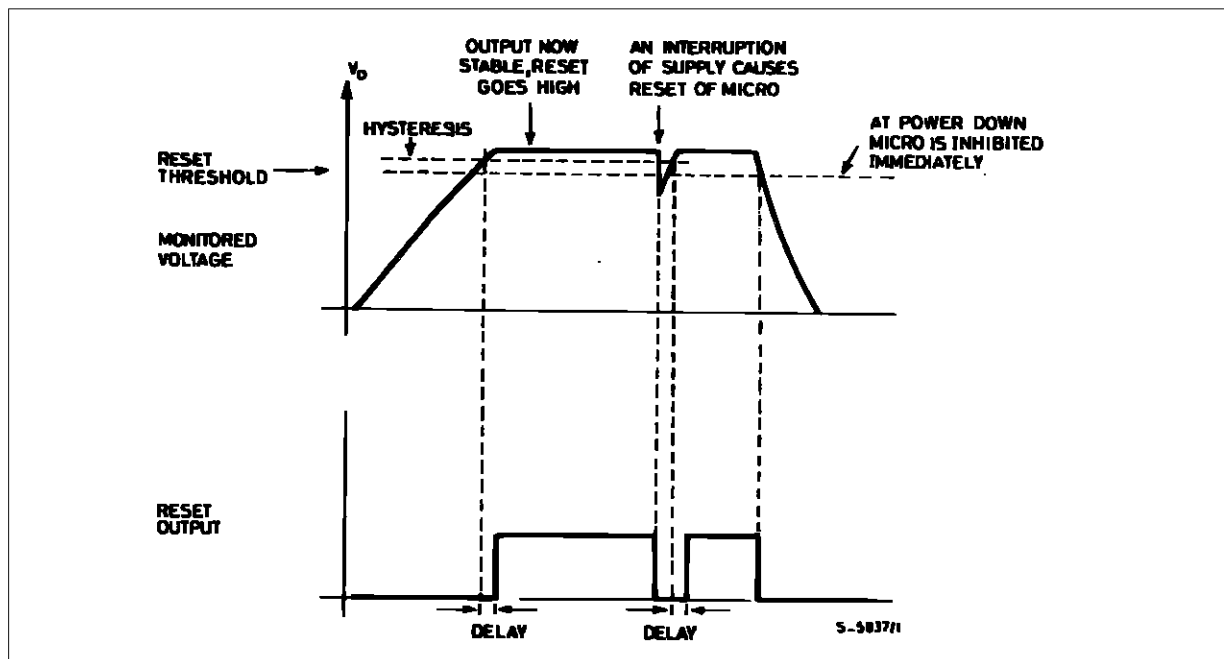

Figure 2 : Soft Start Waveforms

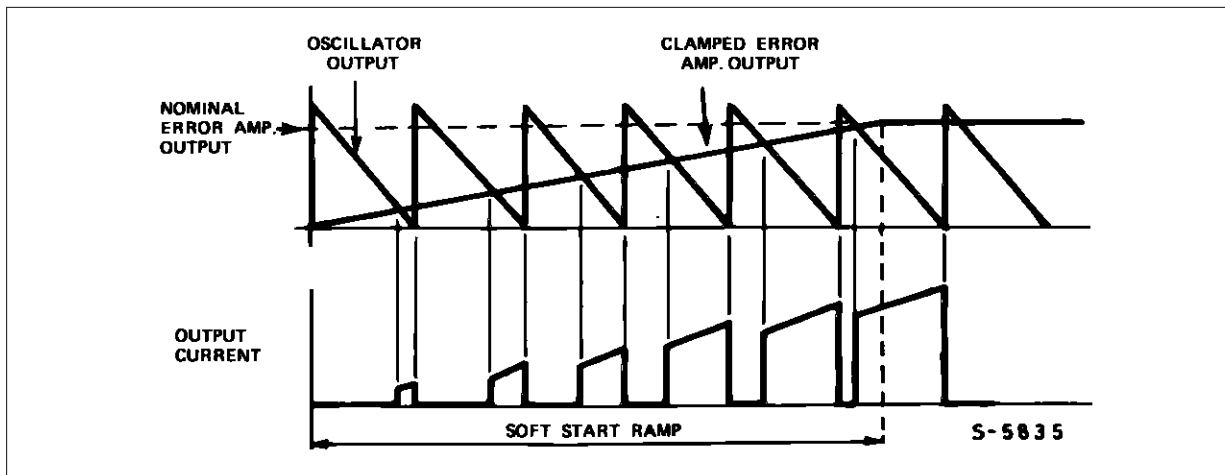
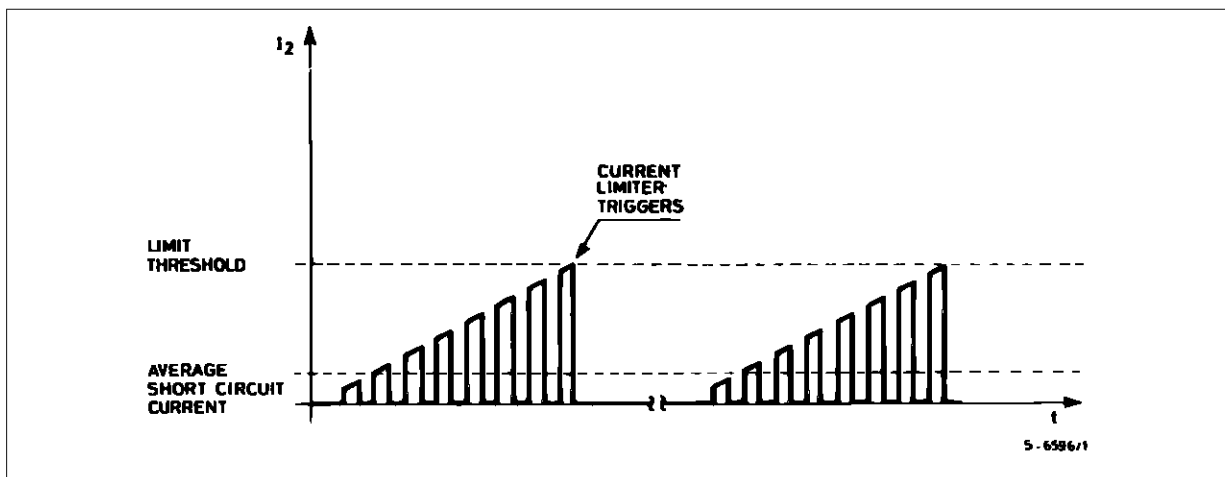

Figure 3 : Current Limiter Waveforms



ABSOLUTE MAXIMUM RATINGS

| Symbol | Parameter | Value | Unit |
|------------------------------|---|-------------|------------------|
| V_i | Input Voltage (pin 3) | 50 | V |
| $V_i - V_2$ | Input to Output Voltage Difference | 50 | V |
| V_2 | Output DC Voltage Output Peak Voltage at $t = 0.1 \mu\text{sec}$ $f = 200\text{KHz}$ | - 1 - 7 | V V |
| V_1, V_{12} | Voltage at Pins 1, 12 | 10 | V |
| V_{15} | Voltage at Pin 15 | 15 | V |
| $V_4, V_5, V_7, V_9, V_{13}$ | Voltage at Pins 4, 5, 7, 9 and 13 | 5.5 | V |
| V_{10}, V_6 | Voltage at Pins 10 and 6 | 7 | V |
| V_{14} | Voltage at Pin 14 ($I_{14} \leq 1 \text{ mA}$) | V_i | |
| I_9 | Pin 9 Sink Current | 1 | mA |
| I_{11} | Pin 11 Source Current | 20 | mA |
| I_{14} | Pin 14 Sink Current ($V_{14} < 5 \text{ V}$) | 50 | mA |
| P_{tot} | Power Dissipation at $T_{\text{case}} \leq 90 \text{ }^\circ\text{C}$ | 20 | W |
| T_j, T_{stg} | Junction and Storage Temperature | - 40 to 150 | $^\circ\text{C}$ |

THERMAL DATA

| Symbol | Parameter | Value | Unit |
|------------------|-------------------------------------|---------|------|
| $R_{th\ j-case}$ | Thermal Resistance Junction-case | Max. 3 | °C/W |
| $R_{th\ j-amb}$ | Thermal Resistance Junction-ambient | Max. 35 | °C/W |

ELECTRICAL CHARACTERISTICS

(refer to the test circuits $T_j = 25^\circ\text{C}$, $V_i = 35\text{V}$, unless otherwise specified)

| Symbol | Parameter | Test Conditions | Min. | Typ. | Max. | Unit | Fig. |
|--------|-----------|-----------------|------|------|------|------|------|
|--------|-----------|-----------------|------|------|------|------|------|

DYNAMIC CHARACTERISTICS (pin 6 to GND unless otherwise specified)

| | | | | | | | |
|-----------------------------------|--|---|-----------|----------|------------|--------|--------|
| V_o | Output Voltage Range | $V_i = 46\text{V}$, $I_o = 1\text{A}$ | V_{ref} | | 40 | V | 4 |
| V_i | Input Voltage Range | $V_o = V_{ref}$ to 36V, $I_o \leq 3\text{A}$ | 9 | | 46 | V | 4 |
| V_i | Input Voltage Range | Note (1), $V_o = V_{REF}$ to 36V, $I_o = 4\text{A}$ | | | 46 | V | 4 |
| ΔV_o | Line Regulation | $V_i = 10\text{V}$ to 40V, $V_o = V_{ref}$, $I_o = 2\text{A}$ | | 15 | 50 | mV | 4 |
| ΔV_o | Load Regulation | $V_o = V_{ref}$ $I_o = 2\text{A}$ to 4A $I_o = 0.5\text{A}$ to 4A | | 10 15 | 30 45 | mV | 4 |
| V_{ref} | Internal Reference Voltage (pin 10) | $V_i = 9\text{V}$ to 46V, $I_o = 2\text{A}$ | 5 | 5.1 | 5.2 | V | 4 |
| $\frac{\Delta V_{ref}}{\Delta T}$ | Average Temperature Coefficient of Reference Voltage | $T_j = 0^\circ\text{C}$ to 125°C , $I_o = 2\text{A}$ | | 0.4 | | mV/°C | |
| V_d | Dropout Voltage Between Pin 2 and Pin 3 | $I_o = 4\text{A}$ $I_o = 2\text{A}$ | | 2 1.3 | 3.2 2.1 | V V | 4 4 |
| I_{2L} | Current Limiting Threshold (pin 2) | L296 - Pin 4 Open, $V_i = 9\text{V}$ to 40V, $V_o = V_{ref}$ to 36V | 4.5 | | 7.5 | A | 4 |
| | | L296P - $V_i = 9\text{V}$ to 40V, $V_o = V_{ref}$ Pin 4 Open $R_{lim} = 22\text{k}\Omega$ | 5 2.5 | | 7 4.5 | A | 4 |
| I_{SH} | Input Average Current | $V_i = 46\text{V}$, Output Short-circuited | | 60 | 100 | mA | 4 |
| η | Efficiency | $I_o = 3\text{A}$ $V_o = V_{ref}$ $V_o = 12\text{V}$ | | 75 85 | | % | 4 |
| SVR | Supply Voltage Ripple Rejection | $\Delta V_i = 2 V_{rms}$, $f_{ripple} = 100\text{Hz}$ $V_o = V_{ref}$, $I_o = 2\text{A}$ | 50 | 56 | | dB | 4 |
| f | Switching Frequency | | 85 | 100 | 115 | kHz | 4 |
| $\frac{\Delta f}{\Delta V_i}$ | Voltage Stability of Switching Frequency | $V_i = 9\text{V}$ to 46V | | 0.5 | | % | 4 |
| $\frac{\Delta f}{\Delta T_j}$ | Temperature Stability of Switching Frequency | $T_j = 0^\circ\text{C}$ to 125°C | | 1 | | % | 4 |
| f_{max} | Maximum Operating Switching Frequency | $V_o = V_{ref}$, $I_o = 1\text{A}$ | 200 | | | kHz | – |
| T_{sd} | Thermal Shutdown Junction Temperature | Note (2) | 135 | 145 | | °C | – |

DC CHARACTERISTICS

| | | | | | | | |
|-----------|-------------------------|---|--|--|----------|----------|----|
| I_{3Q} | Quiescent Drain Current | $V_i = 46\text{V}$, $V_7 = 0\text{V}$, S1 : B, S2 : B $V_6 = 0\text{V}$ $V_6 = 3\text{V}$ | | | 66 30 | 85 40 | mA |
| $-I_{2L}$ | Output Leakage Current | $V_i = 46\text{V}$, $V_6 = 3\text{V}$, S1 : B, S2 : A, $V_7 = 0\text{V}$ | | | | 2 | mA |

Note (1) : Using min. 7 A schottky diode.
(2) : Guaranteed by design, not 100 % tested in production.

L296 - L296P

ELECTRICAL CHARACTERISTICS (continued)

| Symbol | Parameter | Test Conditions | Min. | Typ. | Max. | Unit | Fig. |
|--------|-----------|-----------------|------|------|------|------|------|
|--------|-----------|-----------------|------|------|------|------|------|

SOFT START

| | | | | | | | |
|-------------|----------------|----------------------|----|-----|-----|---------|----|
| $I_{5\ so}$ | Source Current | $V_6 = 0V, V_5 = 3V$ | 80 | 130 | 150 | μA | 6b |
| $I_{5\ si}$ | Sink Current | $V_6 = 3V, V_5 = 3V$ | 50 | 70 | 120 | μA | 6b |

INHIBIT

| | | | | | | | |
|--------------------------|--|---|-----------|--|------------|---------|----|
| V_{6L} V_{6H} | Input Voltage Low Level High Level | $V_i = 9V$ to 46V, $V_7 = 0V$, $S1 : B, S2 : B$ | -0.3 2 | | 0.8 5.5 | V | 6a |
| - I_{6L} - I_{6H} | Input Current with Input Voltage Low Level High Level | $V_i = 9V$ to 46V, $V_7 = 0V$, $S1 : B, S2 : B$ $V_6 = 0.8V$ $V_6 = 2V$ | | | 10 3 | μA | 6a |

ERROR AMPLIFIER

| | | | | | | | |
|---------------|---------------------------|---|-----|--------|----------|--------------------|----------|
| V_{9H} | High Level Output Voltage | $V_{10} = 4.7V, I_9 = 100\mu A$, $S1 : A, S2 : A$ | 3.5 | | | V | 6c |
| V_{9L} | Low Level Output Voltage | $V_{10} = 5.3V, I_9 = 100\mu A$, $S1 : A, S2 : E$ | | | 0.5 | V | 6c |
| $I_{9\ si}$ | Sink Output Current | $V_{10} = 5.3V, S1 : A, S2 : B$ | 100 | 150 | | μA | 6c |
| - $I_{9\ so}$ | Source Output Current | $V_{10} = 4.7V, S1 : A, S2 : D$ | 100 | 150 | | μA | 6c |
| I_{10} | Input Bias Current | $V_{10} = 5.2V, S1 : B$ $V_{10} = 6.4V, S1 : B, L296P$ | | 2 2 | 10 10 | μA μA | 6c 6c |
| G_v | DC Open Loop Gain | $V_9 = 1V$ to 3V, $S1 : A, S2 : C$ | 46 | 55 | | dB | 6c |

OSCILLATOR AND PWM COMPARATOR

| | | | | | | | |
|------------|---|-------------------------------|---|--|---|---------|----|
| - I_7 | Input Bias Current of PWM Comparator | $V_7 = 0.5V$ to 3.5V | | | 5 | μA | 6a |
| - I_{11} | Oscillator Source Current | $V_{11} = 2V, S1 : A, S2 : B$ | 5 | | | mA | |

RESET

| | | | | | | | |
|--------------------------------|--|---|---------------------|---------------------|---------------------|---------------|----|
| $V_{12\ R}$ | Rising Threshold Voltage | $V_i = 9V$ to 46V, $S1 : B, S2 : B$ | V_{ref} -150mV | V_{ref} -100mV | V_{ref} -50mV | V | 6d |
| $V_{12\ F}$ | Falling Threshold Voltage | | 4.75 | V_{ref} -150mV | V_{ref} -100mV | V | 6d |
| $V_{13\ D}$ | Delay Thershold Voltage | $V_{12} = 5.3V, S1 : A, S2 : B$ | 4.3 | 4.5 | 4.7 | V | 6d |
| $V_{13\ H}$ | Delay Threshold Voltage Hysteresis | | | 100 | | mV | 6d |
| $V_{14\ S}$ | Output Saturation Voltage | $I_{14} = 16mA, V_{12} = 4.7V, S1, S2 : B$ | | | 0.4 | V | 6d |
| I_{12} | Input Bias Current | $V_{12} = 0V$ to $V_{ref}, S1 : B, S2 : B$ | | 1 | 3 | μA | 6d |
| - $I_{13\ so}$ $I_{13\ si}$ | Delay Source Current Delay Sink Current | $V_{13} = 3V, S1 : A, S2 : B$ $V_{12} = 5.3V$ $V_{12} = 4.7V$ | 70 10 | 110 | 140 | μA mA | 6d |
| I_{14} | Output Leakage Current | $V_i = 46V, V_{12} = 5.3V, S1 : B, S2 : A$ | | | 100 | μA | 6d |

CROWBAR

| | | | | | | | |
|------------|---------------------------|---|-----|-----|-----|---------|----|
| V_1 | Input Threshold Voltage | $S1 : B$ | 5.5 | 6 | 6.4 | V | 6b |
| V_{15} | Output Saturation Voltage | $V_i = 9V$ to 46V, $V_i = 5.4V$, $I_{15} = 5mA, S1 : A$ | | 0.2 | 0.4 | V | 6b |
| I_1 | Input Bias Current | $V_1 = 6V, S1 : B$ | | | 10 | μA | 6b |
| - I_{15} | Output Source Current | $V_i = 9V$ to 46V, $V_1 = 6.5V$, $V_{15} = 2V, S1 : B$ | 70 | 100 | | mA | 6b |

Figure 4 : Dynamic Test Circuit

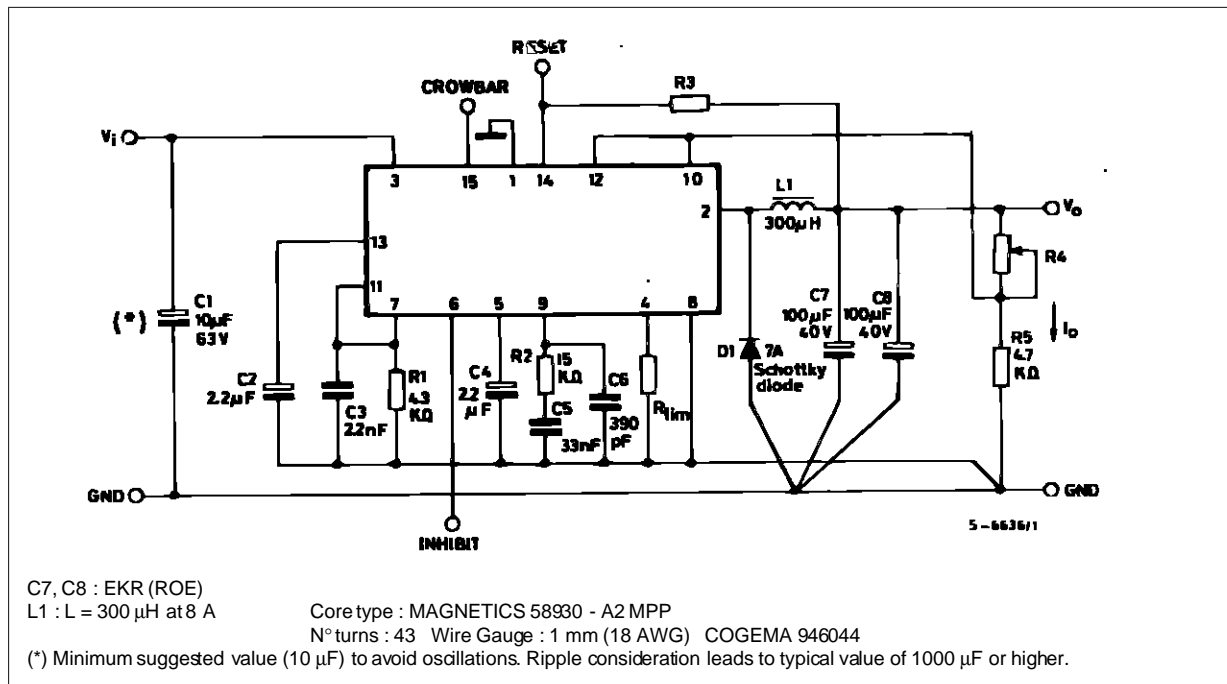

Figure 5 : PC. Board and Component Layout of the Circuit of Figure 4 (1:1 scale)

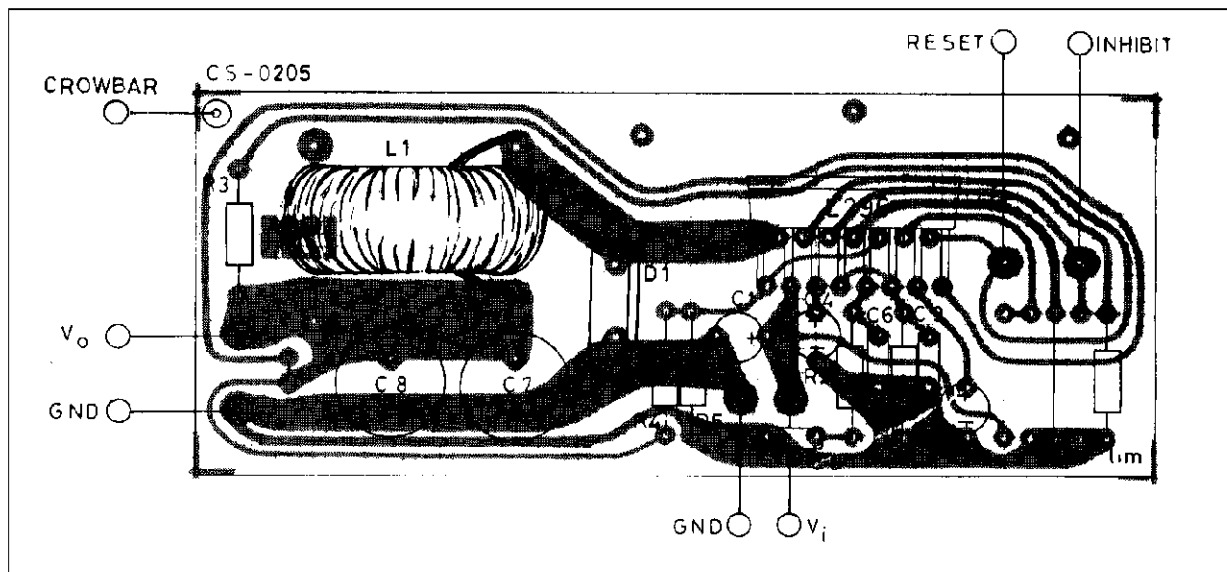

Figure 6 : DC Test Circuits.

Figure 6a.

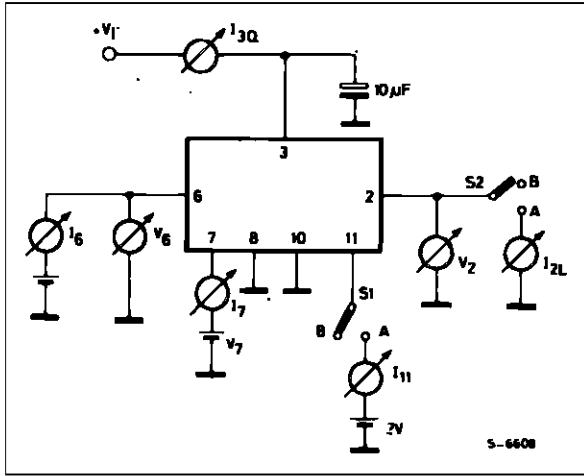

Figure 6b.

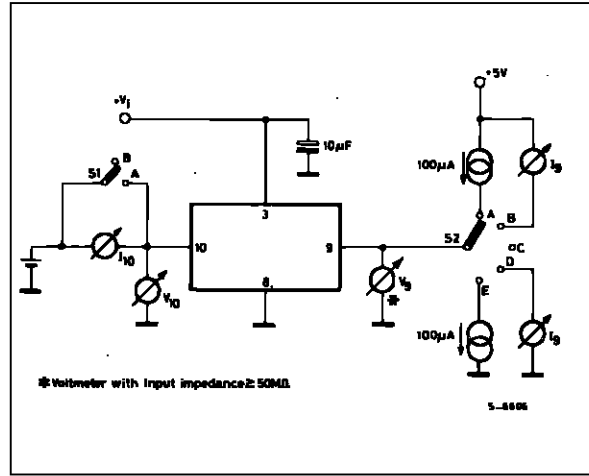
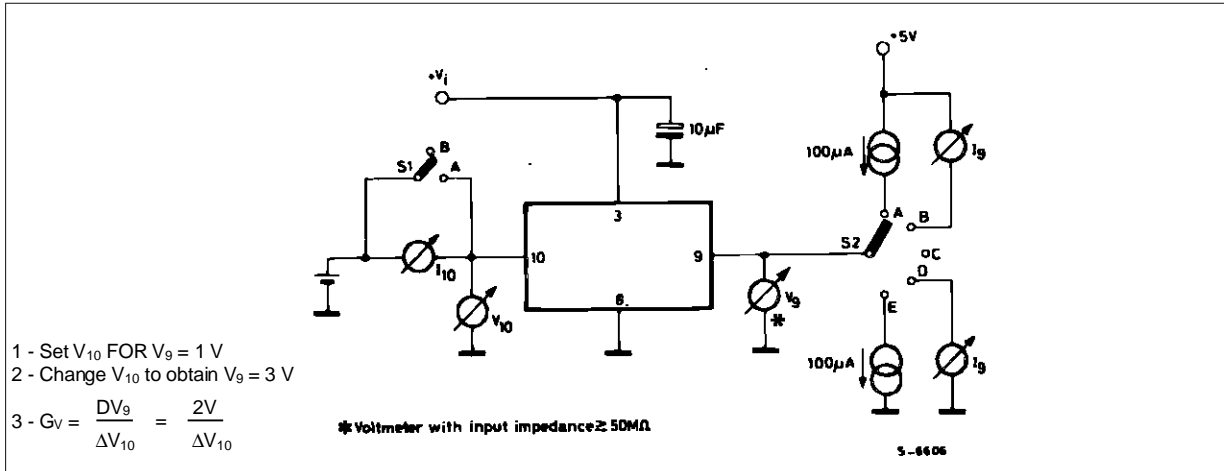

Figure 6c.



- 1 - Set V_{10} FOR $V_9 = 1 V$
- 2 - Change V_{10} to obtain $V_9 = 3 V$
- 3 - $G_v = \frac{\Delta V_9}{\Delta V_{10}} = \frac{2V}{\Delta V_{10}}$

Figure 6d.

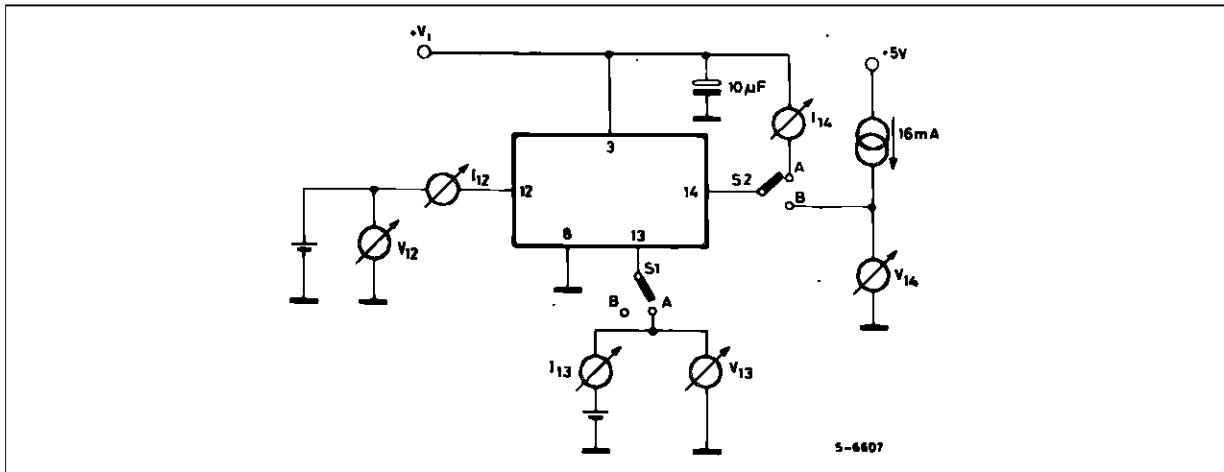

Figure 7 : Quiescent Drain Current vs. Supply Voltage (0 % Duty Cycle - see fig. 6a).

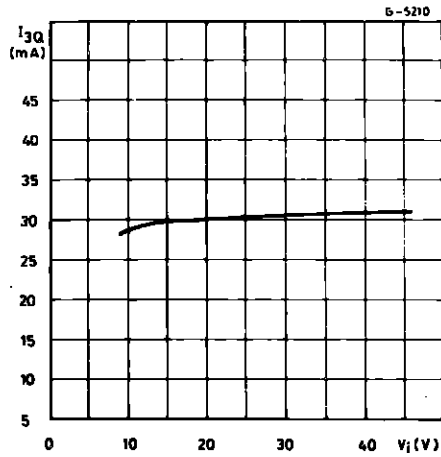

Figure 8 : Quiescent Drain Current vs. Supply Voltage (100 % Duty Cycle see fig. 6a).

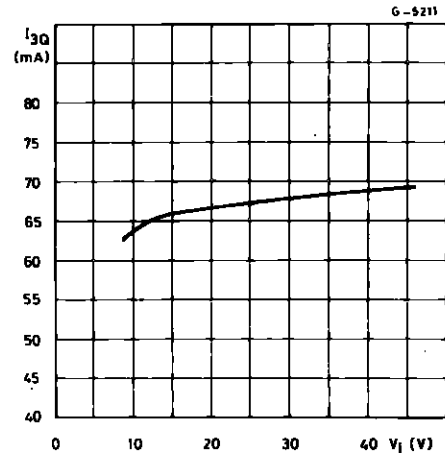

Figure 9 : Quiescent Drain Current vs. Junction Temperature (0 % Duty Cycle - see fig. 6a).

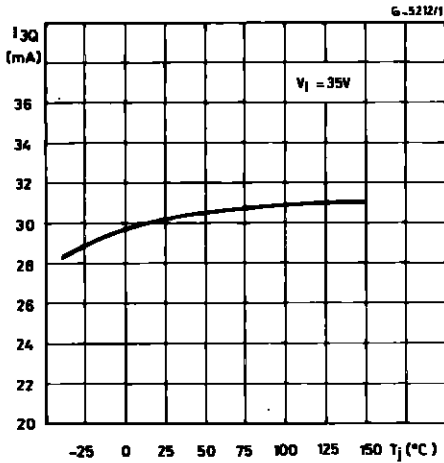

Figure 10 : Quiescent Drain Current vs. Junction Temperature (100 % Duty Cycle - see fig. 6a).

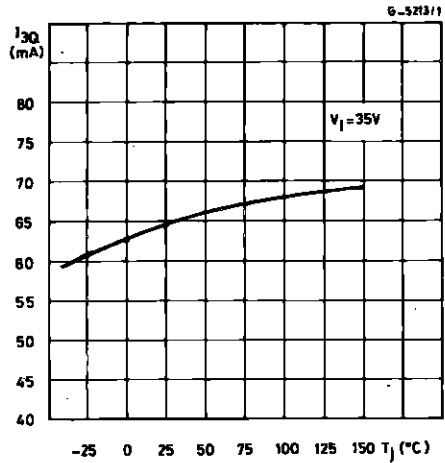

Figure 11 : Reference Voltage (pin 10) vs. V_I (see fig. 4).

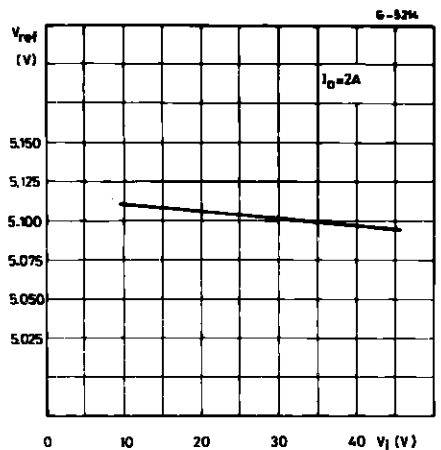

Figure 12 : Reference Voltage (pin 10) vs. Junction Temperature (see fig. 4).

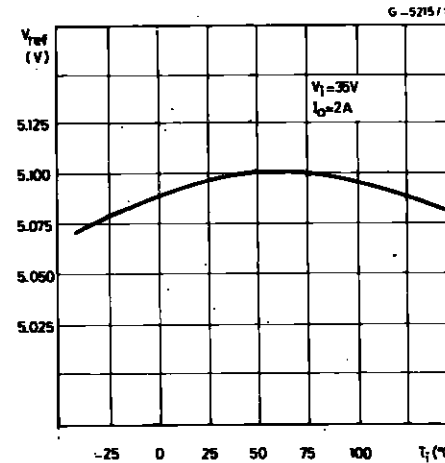

Figure 13 : Open Loop Frequency and Phase Response of Error Amplifier (see fig. 6c).

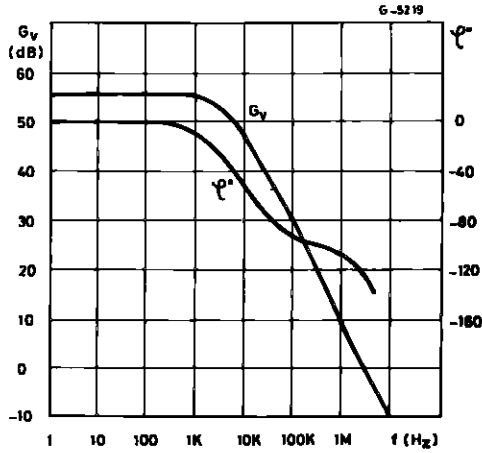

Figure 14 : Switching Frequency vs. Input Voltage (see fig. 4).

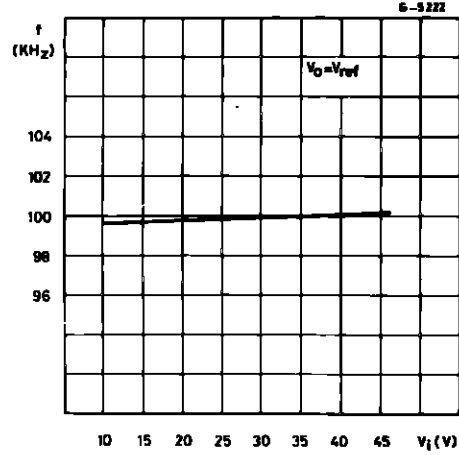

Figure 15 : Switching Frequency vs. Junction Temperature (see fig. 4).

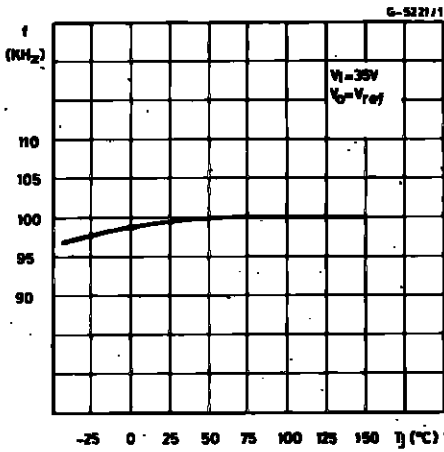

Figure 16 : Switching Frequency vs. R1 (see fig. 4).

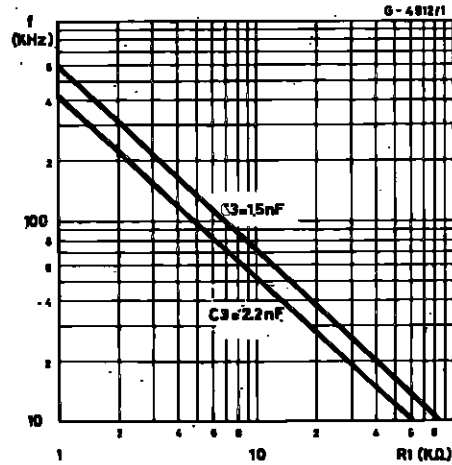

Figure 17 : Line Transient Response (see fig. 4).

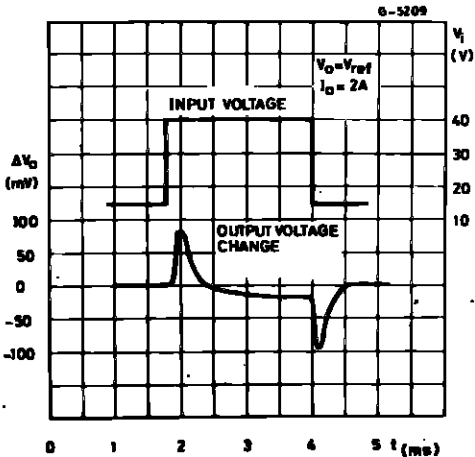

Figure 18 : Load Transient Response (see fig. 4).

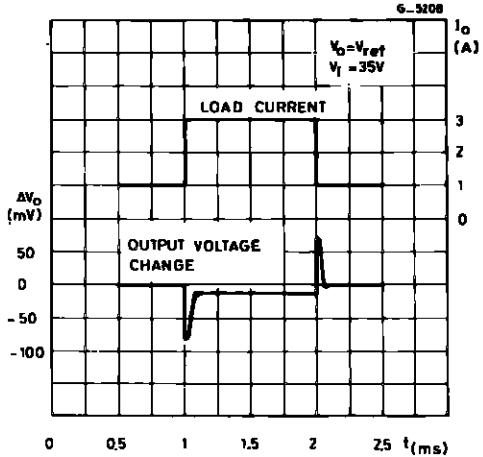

Figure 19 : Supply Voltage Ripple Rejection vs. Frequency (see fig. 4).

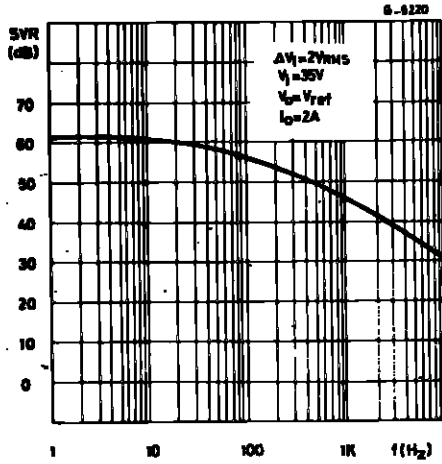

Figure 21 : Dropout Voltage Between Pin 3 and Pin 2 vs. Junction Temperature.

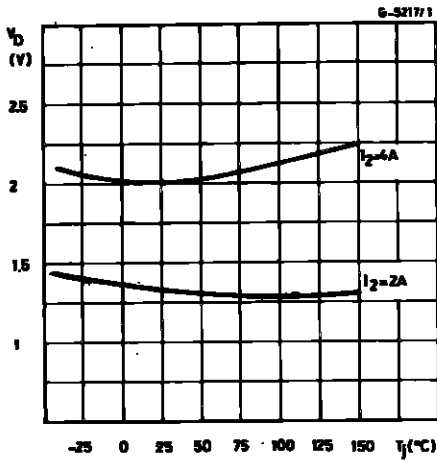

Figure 23 : Power Dissipation (device only) vs. Input Voltage.

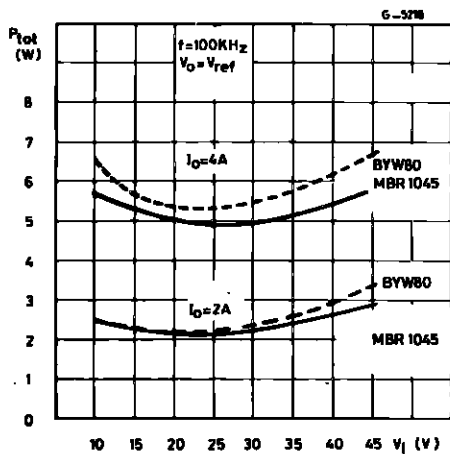

Figure 20 : Dropout Voltage Between Pin 3 and Pin 2 vs. Current at Pin 2.

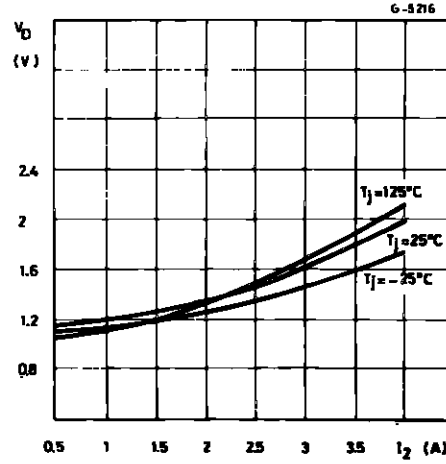

Figure 22 : Power Dissipation Derating Curve.

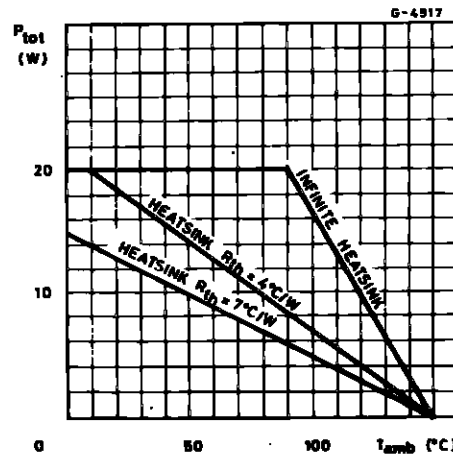

Figure 24 : Power Dissipation (device only) vs. Input voltage.

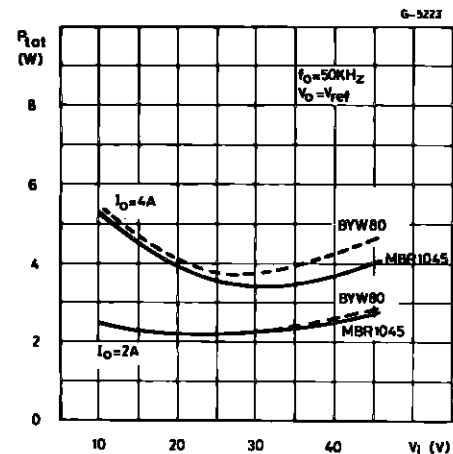

Figure 25 : Power Dissipation (device only) vs. Output Voltage (see fig. 4).

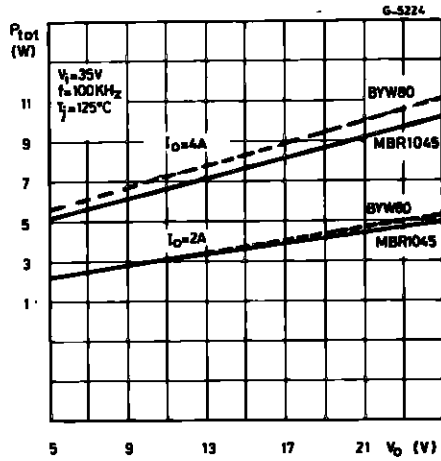

Figure 26 : Power Dissipation (device only) vs. Output Voltage (see fig. 4).

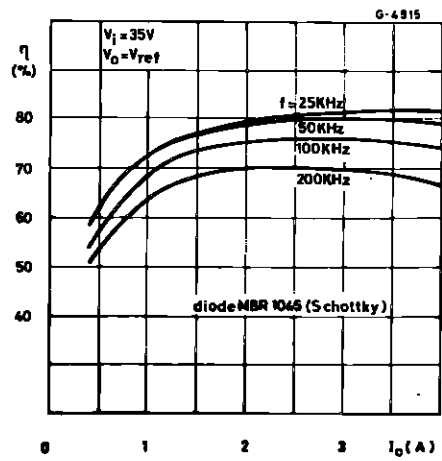

Figure 27 : Voltage and Current Waveforms at Pin 2 (see fig. 4).

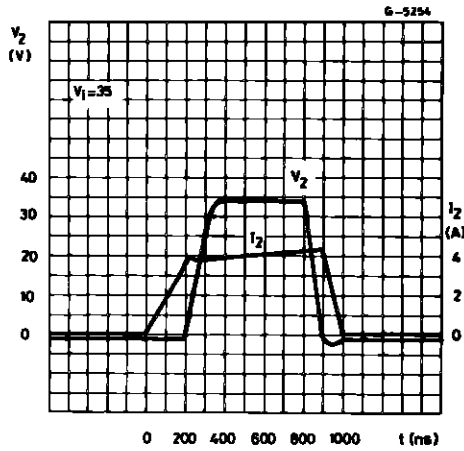

Figure 28 : Efficiency vs. Output Current.

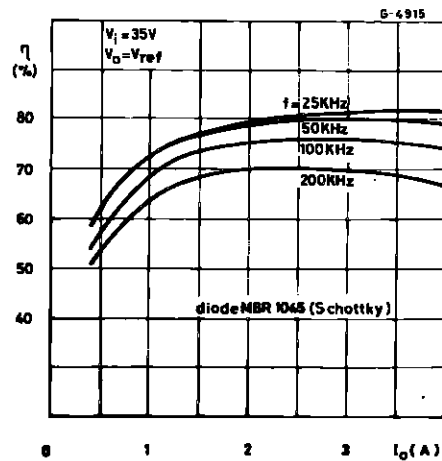

Figure 29 : Efficiency vs. Output Voltage.

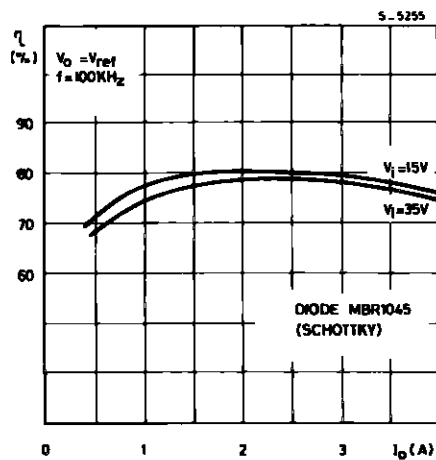

Figure 30 : Efficiency vs. Output Voltage.

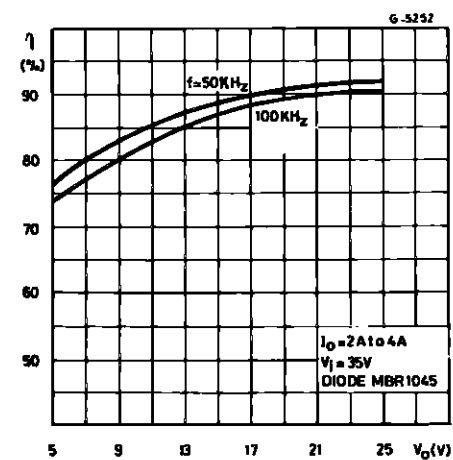

Figure 31 : Current Limiting Threshold vs. $R_{pin\ 4}$ (L296P only).

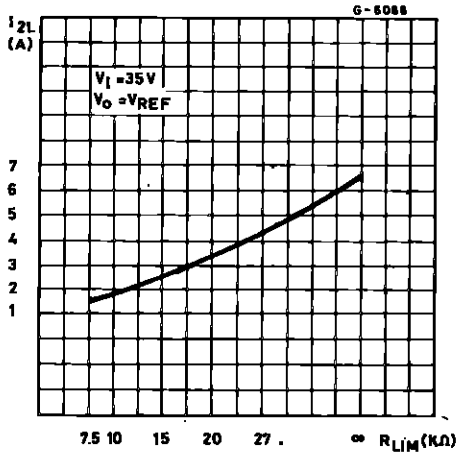

Figure 32 : Current Limiting Threshold vs. Junction Temperature.

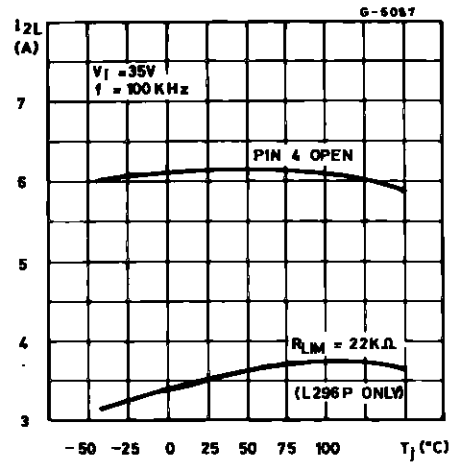
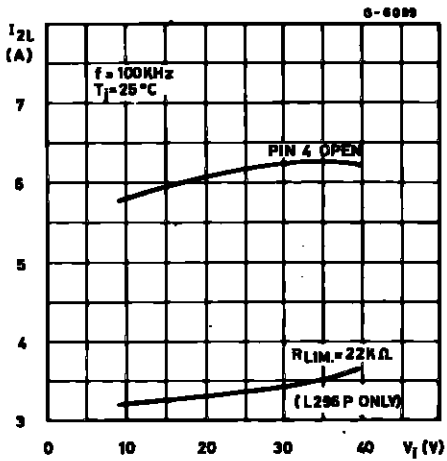
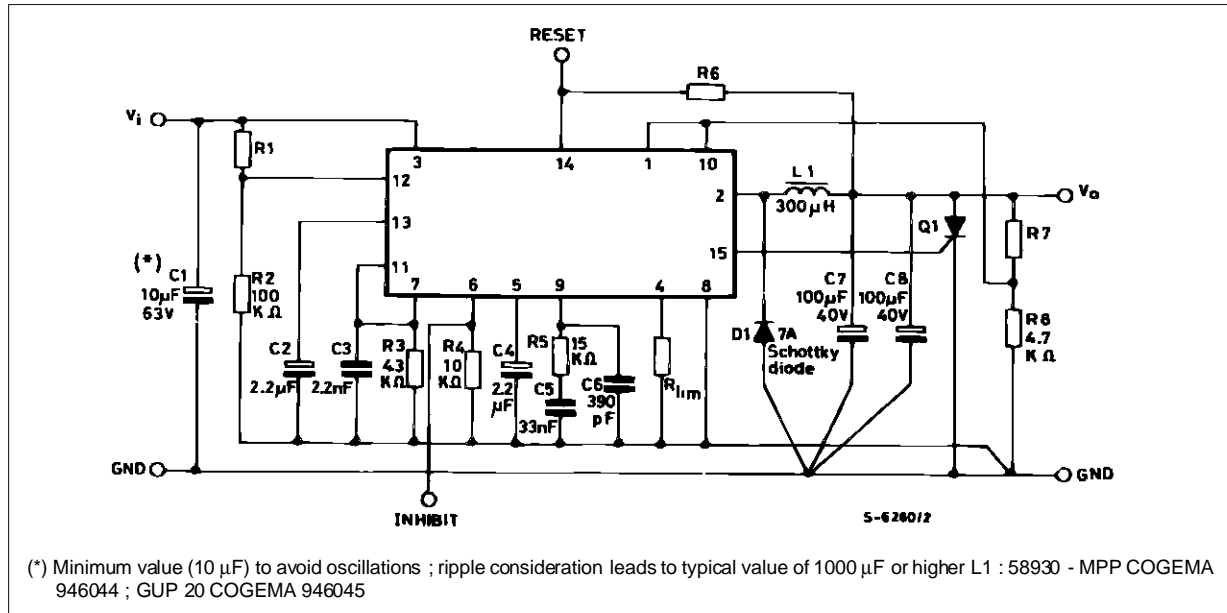

Figure 33 : Current Limiting Threshold vs. Supply Voltage.



APPLICATION INFORMATION

Figure 34 : Typical Application Circuit.



SUGGESTED INDUCTOR (L1)

| Core Type | No Turns | Wire Gauge | Air Gap |
|---|----------|------------|---------|
| Magnetics 58930 – A2MPP | 43 | 1.0 mm | – |
| Thomson GUP 20 x 16 x 7 | 65 | 0.8 mm | 1 mm |
| Siemens EC 35/17/10 (B6633& – G0500 – X127) | 40 | 2 x 0.8 mm | – |

VOGT 250 µH Toroidal Coil, Part Number 5730501800

| Resistor Values for Standard Output Voltages | | |
|--|--------|--------|
| Vo | R8 | R7 |
| 12 V | 4.7 KΩ | 6.2 KΩ |
| 15 V | 4.7 KΩ | 9.1 KΩ |
| 18 V | 4.7 KΩ | 12 KΩ |
| 24 V | 4.7 KΩ | 18 KΩ |

Figure 35 : P.C. Board and Component Layout of the Circuit of fig. 34 (1:1 scale)

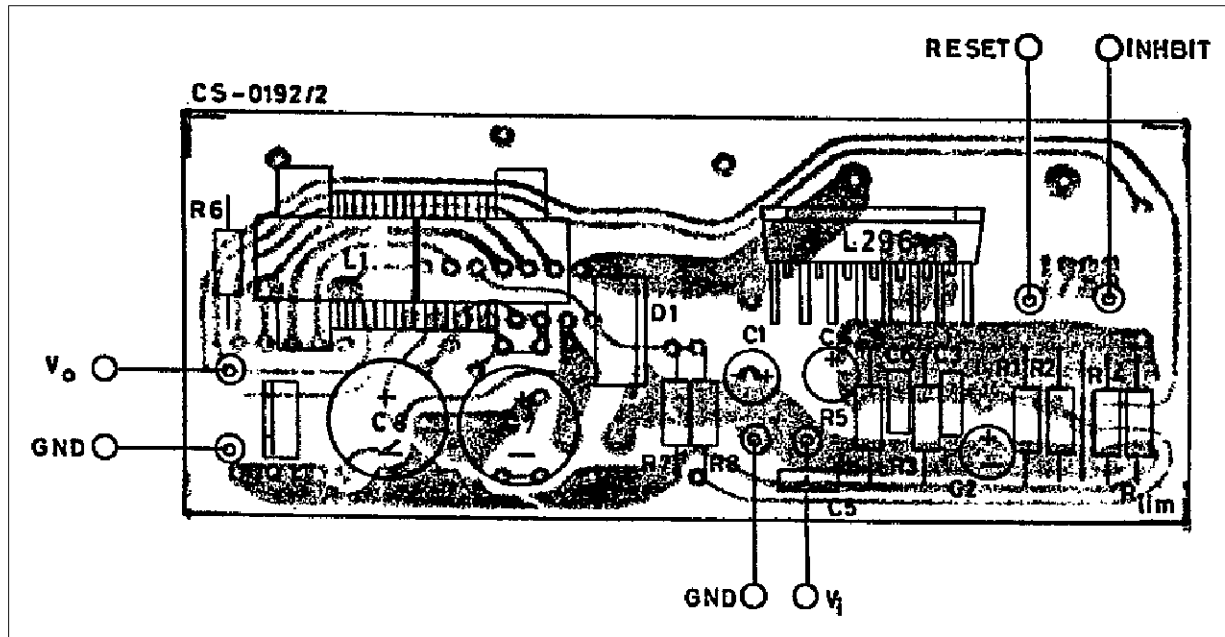

SELECTION OF COMPONENT VALUES (see fig. 34)

| Component | Recommended Value | Purpose | Allowed Range | | Notes |
|------------------|----------------------------|--|---------------------|------------------|---|
| | | | Min. | Max. | |
| R1 R2 | – 100 k Ω | Set Input Voltage Threshold for Reset. | – | 220k Ω | $R1/R2 = \frac{V_{i\ min}}{5} - 1$ If output voltage is sensed R1 and R2 may be limited and pin 12 connected to pin 10. |
| R3 | 4.3 k Ω | Sets Switching Frequency | 1 k Ω | 100k Ω | |
| R4 | 10 k Ω | Pull-down Resistor | | 22k Ω | May be omitted and pin 6 grounded if inhibit not used. |
| R5 | 15 k Ω | Frequency Compensation | 10k Ω | | |
| R6 | | Collector Load For Reset Output | $\frac{V_o}{0.05A}$ | | Omitted if reset function not used. |
| R7 R8 | – 4.7 k Ω | Divider to Set Output Voltage | – | – 1k Ω | $R7/R8 = \frac{V_o - V_{REF}}{V_{REF}}$ |
| R _{lim} | – | Sets Current Limit Level | 7.5k Ω | | If R _{lim} is omitted and pin 4 left open the current limit is internally fixed. |
| C1 | 10 μ F | Stability | 2.2 μ F | | |
| C2 | 2.2 μ F | Sets Reset Delay | – | – | Omitted if reset function not used. |
| C3 | 2.2 nF | Sets Switching Frequency | 1 nF | 3.3nF | |
| C4 | 2.2 μ F | Soft Start | 1 μ F | – | Also determines average short circuit current. |
| C5 | 33 nF | Frequency Compensation | | | |
| C6 | 390 pF | High Frequency Compensation | – | – | Not required for 5 V operation. |
| C7, C8 L1 | 100 μ F 300 μ H | Output Filter | – 100 μ H | – | |
| Q1 | | Crowbar Protection | | | The SCR must be able to withstand the peak discharge current of the output capacitor and the short circuit current of the device. |
| D1 | | Recirculation Diode | | | 7A Schottky or 35 ns t_{rr} Diode. |

L296 - L296P

Figure 36 : A Minimal 5.1 V Fixed Regulator. Very Few Components are Required.

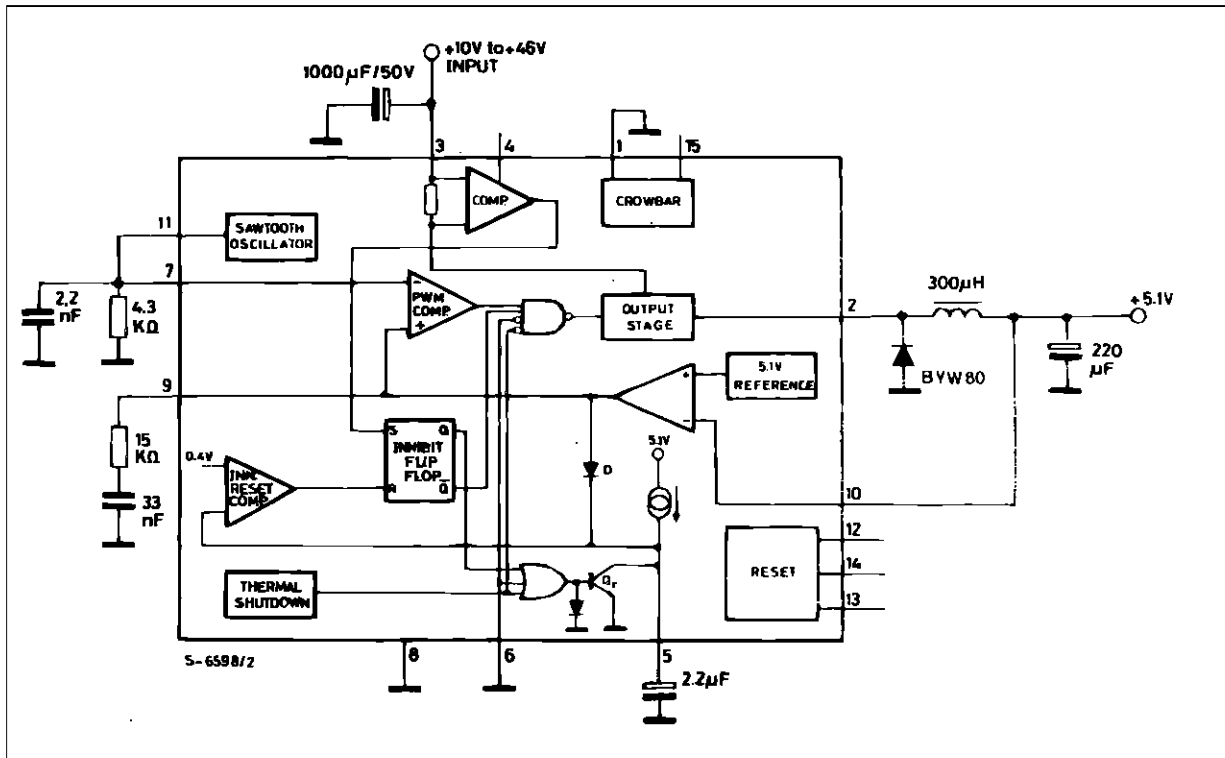

Figure 37 : 12 V/10 A Power Supply.

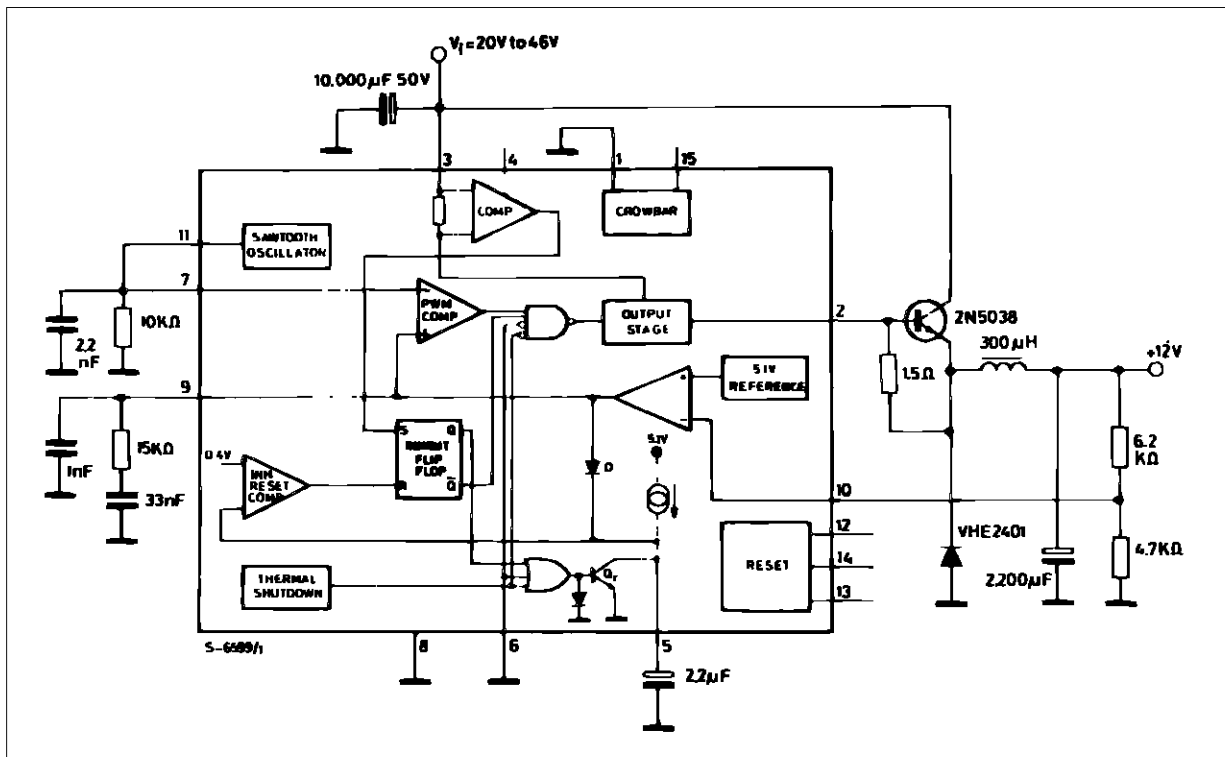

Figure 38 : Programmable Power Supply.

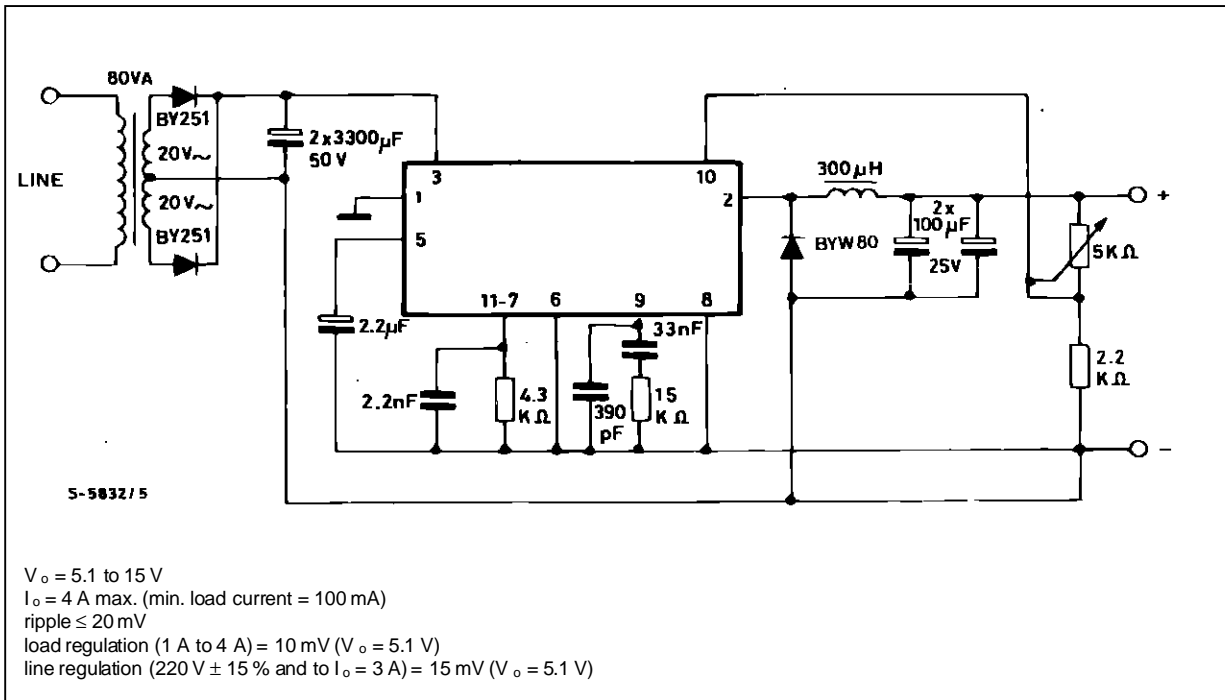
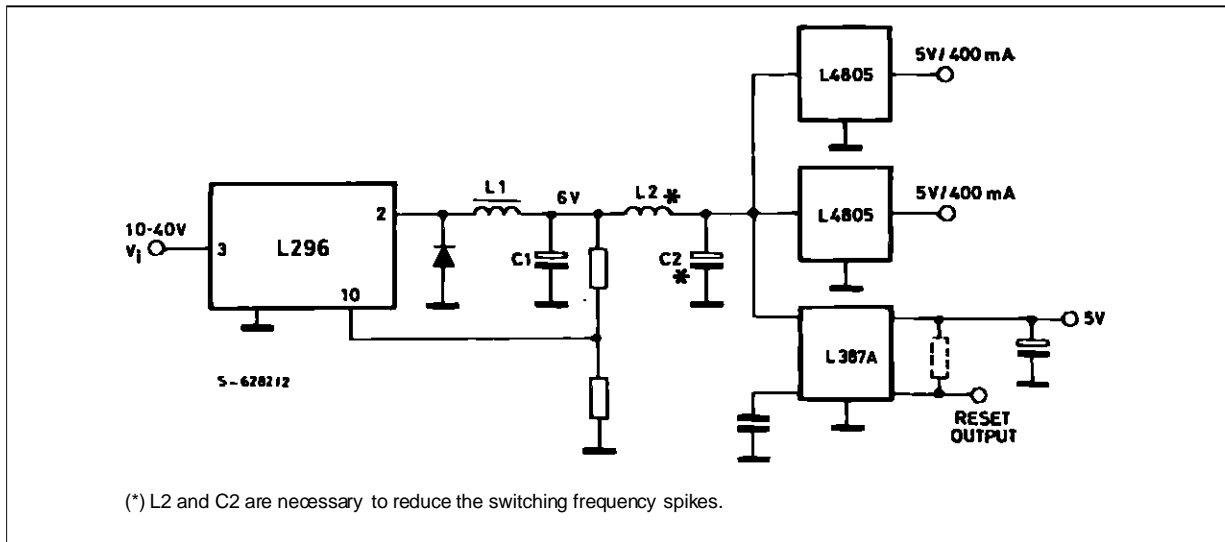

Figure 39 : Preregulator for Distributed Supplies.



L296 - L296P

Figure 40 : In Multiple Supplies Several L296s can be Synchronized As Shown.

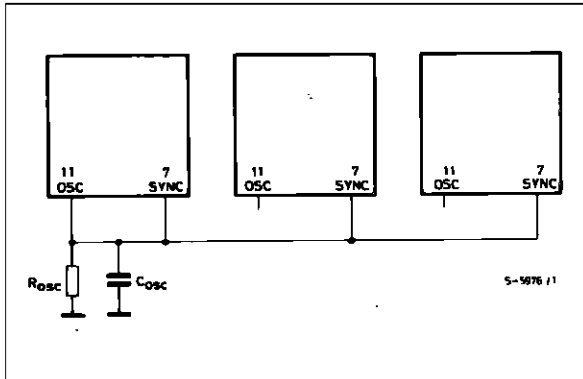

Figure 41 : Voltage Sensing for Remote Load.

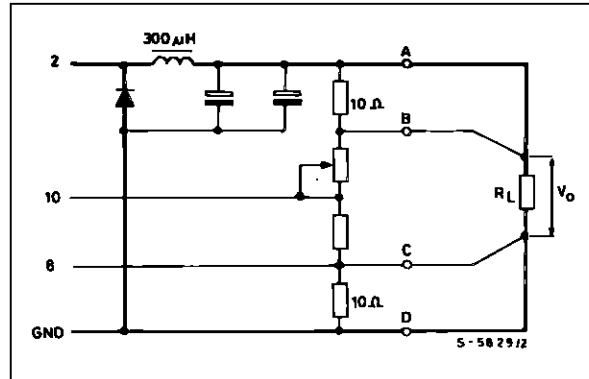

Figure 42 : A 5.1 V/15 V/24 V Multiple Supply. Note the Synchronization of the Three L296s.

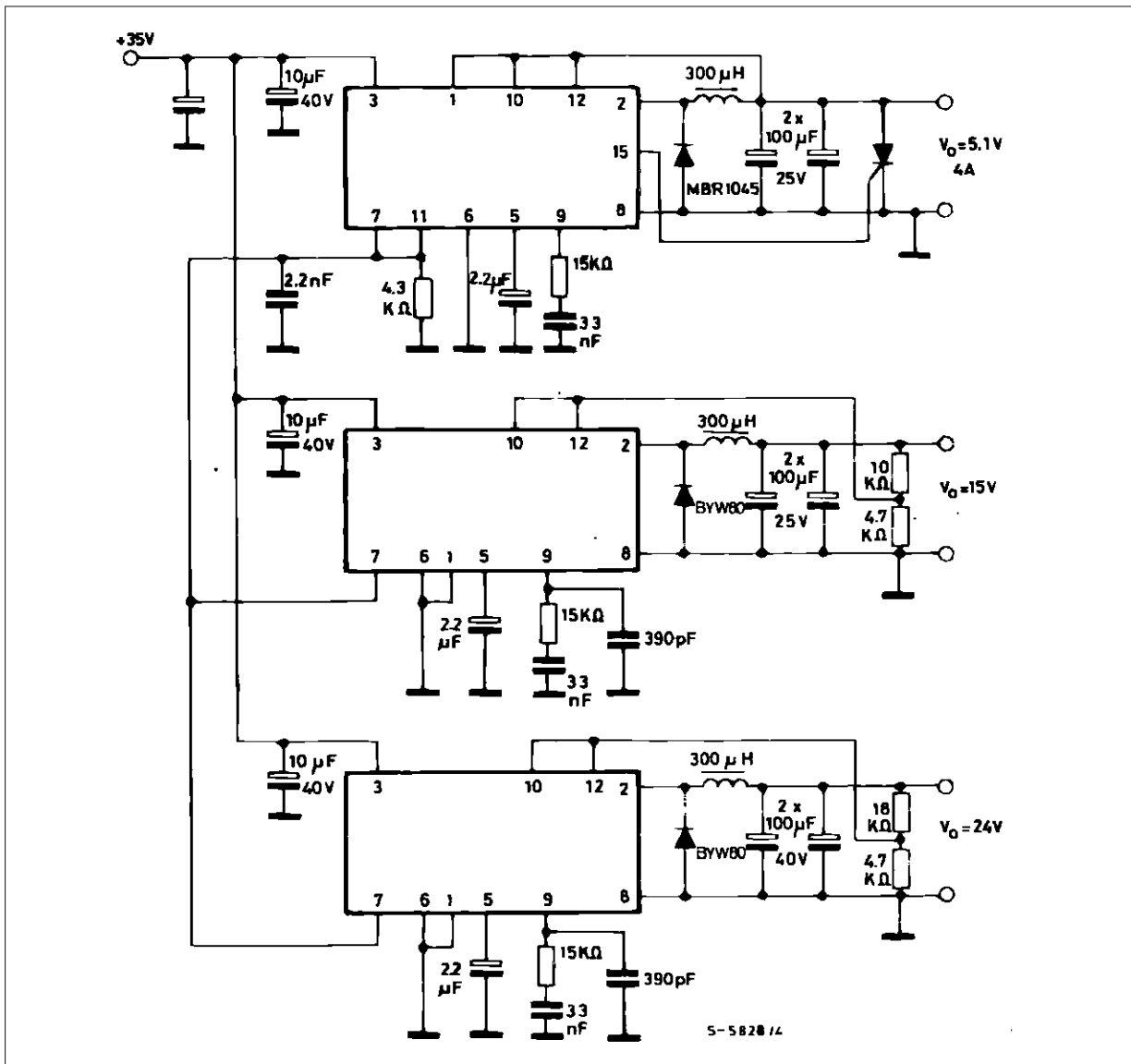
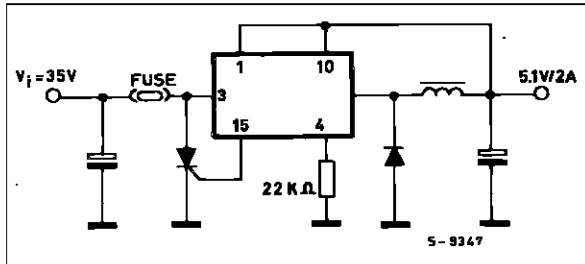

Figure 43 : 5.1V/2A Power Supply using External Limiting Current Resistor and Crowbar Protection on the Supply Voltage (L296P only)



SOFT-START AND REPETITIVE POWER-ON

When the device is repetitively powered-on, the soft-start capacitor, C_{SS} , must be discharged rapidly to ensure that each start is "soft". This can be achieved economically using the reset circuit, as shown in Figure 44.

In this circuit the divider R1, R2 connected to pin 12 determines the minimum supply voltage, below which the open collector transistor at the pin 14 output discharges C_{SS} .

Figure 44

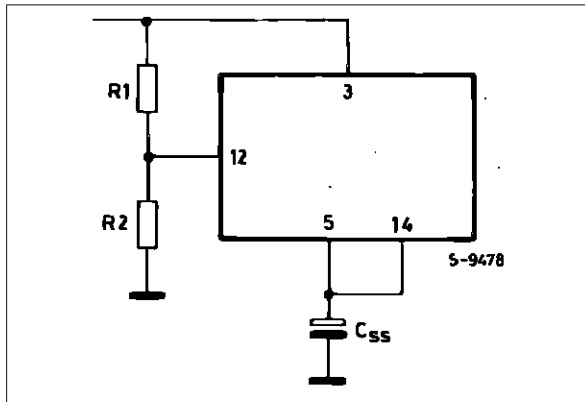

The approximate discharge times obtained with this circuit are :

| C_{SS} (μF) | t_{DIS} (μs) |
|----------------------|-----------------------|
| 2.2 | 200 |
| 4.7 | 300 |
| 10 | 600 |

If these times are still too long, an external PNP tran-

sistor may be added, as shown in Figure 45 ; with this circuit discharge times of a few microseconds may be obtained.

Figure 45

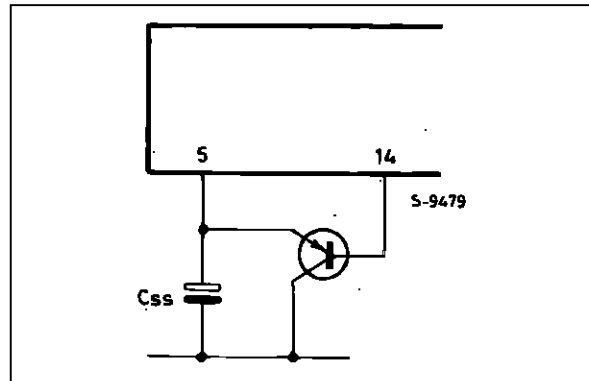

HOW TO OBTAIN BOTH RESET AND POWER FAIL

Figure 46 illustrates how it is possible to obtain at the same time both the power fail and reset functions simply by adding one diode (D) and one resistor (R).

In this case the Reset delay time (pin 13) can only start when the output voltage is $V_O \geq V_{REF} - 100mV$ and the voltage across R2 is higher than 4.5V.

With the hysteresis resistor it is possible to fix the input pin 12 hysteresis in order to increase immunity to the 100Hz ripple present on the supply voltage.

Moreover, the power fail and reset delay time are automatically locked to the soft-start. Soft-start and delayed reset are thus two sequential functions.

The hysteresis resistor should be in the range of about 100kΩ and the pull-up resistor of 1 to 2.2kΩ.

Figure 46

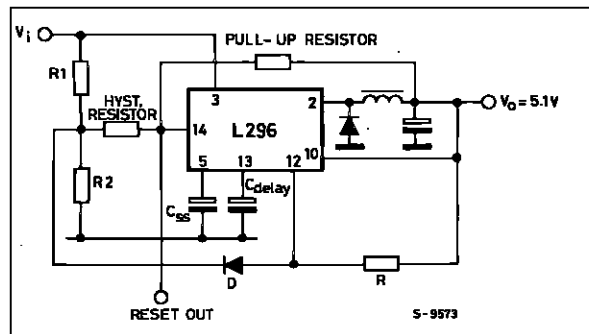

MULTIWATT15 VERTICAL PACKAGE MECHANICAL DATA

| Dimensions | Millimeters | | | Inches | | |
|------------|-------------|-------|-------|--------|-------|-------|
| | Min. | Typ. | Max. | Min. | Typ. | Max. |
| A | | | 5 | | | 0.197 |
| B | | | 2.65 | | | 0.104 |
| C | | | 1.6 | | | 0.063 |
| D | | 1 | | | 0.039 | |
| E | 0.49 | | 0.55 | 0.019 | | 0.022 |
| F | 0.66 | | 0.75 | 0.026 | | 0.030 |
| G | 1.14 | 1.27 | 1.4 | 0.045 | 0.050 | 0.055 |
| G1 | 17.57 | 17.78 | 17.91 | 0.692 | 0.700 | 0.705 |
| H1 | 19.6 | | | 0.772 | | |
| H2 | | | 20.2 | | | 0.795 |
| L | 22.1 | | 22.6 | 0.870 | | 0.890 |
| L1 | 22 | | 22.5 | 0.866 | | 0.886 |
| L2 | 17.65 | | 18.1 | 0.695 | | 0.713 |
| L3 | 17.25 | 17.5 | 17.75 | 0.679 | 0.689 | 0.699 |
| L4 | 10.3 | 10.7 | 10.9 | 0.406 | 0.421 | 0.429 |
| L7 | 2.65 | | 2.9 | 0.104 | | 0.114 |
| M | 4.2 | 4.3 | 4.6 | 0.165 | 0.169 | 0.181 |
| M1 | 4.5 | 5.08 | 5.3 | 0.177 | 0.200 | 0.209 |
| S | 1.9 | | 2.6 | 0.075 | | 0.102 |
| S1 | 1.9 | | 2.6 | 0.075 | | 0.102 |
| Dia. 1 | 3.65 | | 3.85 | 0.144 | | 0.152 |

MUL15V.TBL

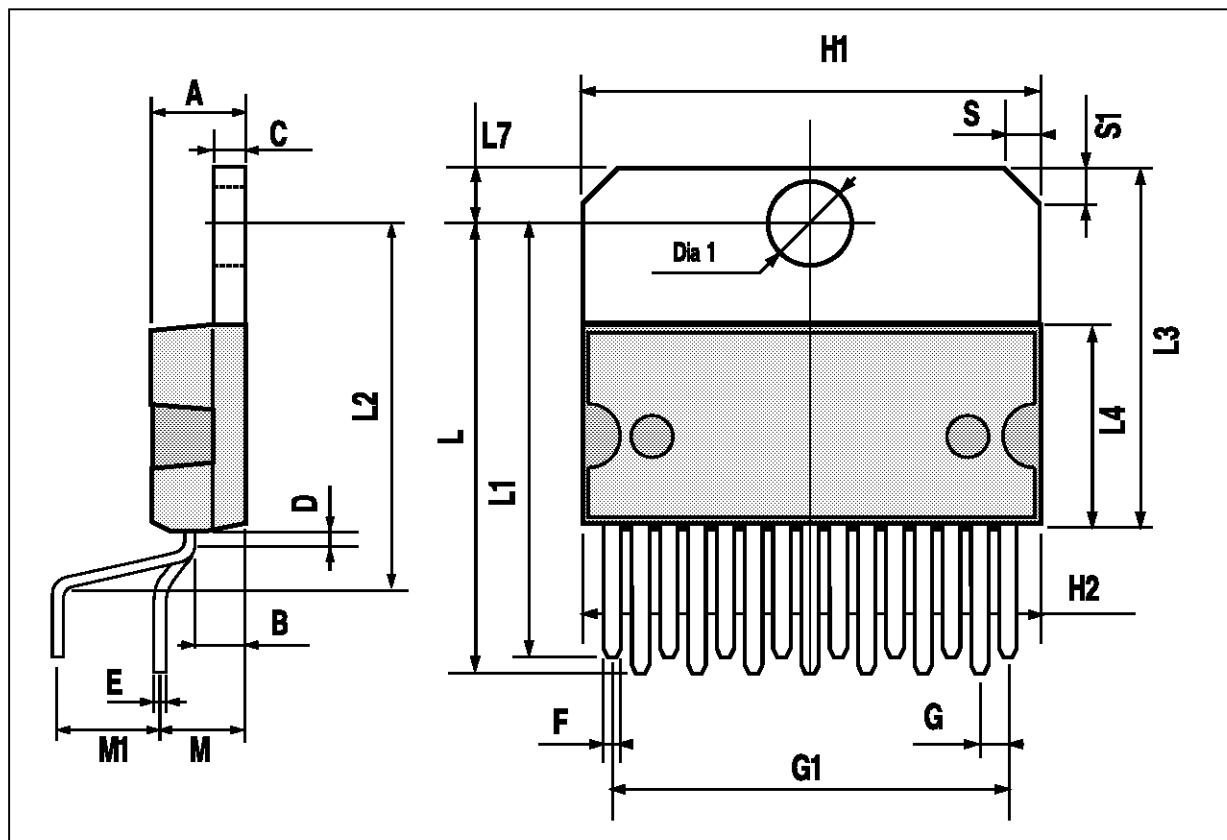

PMUL15V.EPS

Information furnished is believed to be accurate and reliable. However, SGS-THOMSON Microelectronics assumes no responsibility for the consequences of use of such information nor for any infringement of patents or other rights of third parties which may result from its use. No license is granted by implication or otherwise under any patent or patent rights of SGS-THOMSON Microelectronics. Specifications mentioned in this publication are subject to change without notice. This publication supersedes and replaces all information previously supplied. SGS-THOMSON Microelectronics products are not authorized for use as critical components in life support devices or systems without express written approval of SGS-THOMSON Microelectronics.

© 1994 SGS-THOMSON Microelectronics - All Rights Reserved

SGS-THOMSON Microelectronics GROUP OF COMPANIES
Australia - Brazil - France - Germany - Hong Kong - Italy - Japan - Korea - Malaysia - Malta - Morocco - The Netherlands - Singapore -
Spain - Sweden - Switzerland - Taiwan - Thailand - United Kingdom - U.S.A.