

78K0 family

Product Letter

μPD78005x

8-bit Microcontrollers

Description

The single-chip μPD78005x microcontrollers are members of NEC's successful 8-bit 78K0 family. They integrate CPU, ROM, RAM and a wealth of different peripheral functions on chip, to suit even complex system requirements. All devices have built-in serial interfaces, A/D and D/A converters, but are available with or without a multimaster I²C Bus interface. Memory options are listed in the ordering information table.

Applications

μPD78005x devices are designed for use in car audio systems, printers, audio/video systems and communications equipment, including cordless telephones and pagers. Their excellent electromagnetic compatibility (EMC) makes them an ideal choice for automotive applications.

Features

- Mask ROM and Flash versions
- 0.4 μs min. instruction execution time (5 MHz clock)
- Powerful instruction set
- Bit manipulation instructions
- Multiply and divide instructions
- 3 serial interfaces
- A/D converter: 8-channel 8-bit
- D/A converter: 2-channel 8-bit
- 8/16-bit timer/counter
- PWM output
- Buzzer output
- 68 I/O ports
- Real-time output port
- Interrupt controller
- Clock generator
- Real-time subsystem clock
- Clock prescaler with 4 gears
- Standby control (HALT, STOP mode)
- Power supply voltage: 1.8 – 5.5 V
- High electromagnetic compatibility
- 80-pin QFP or TQFP packages

Block Diagram

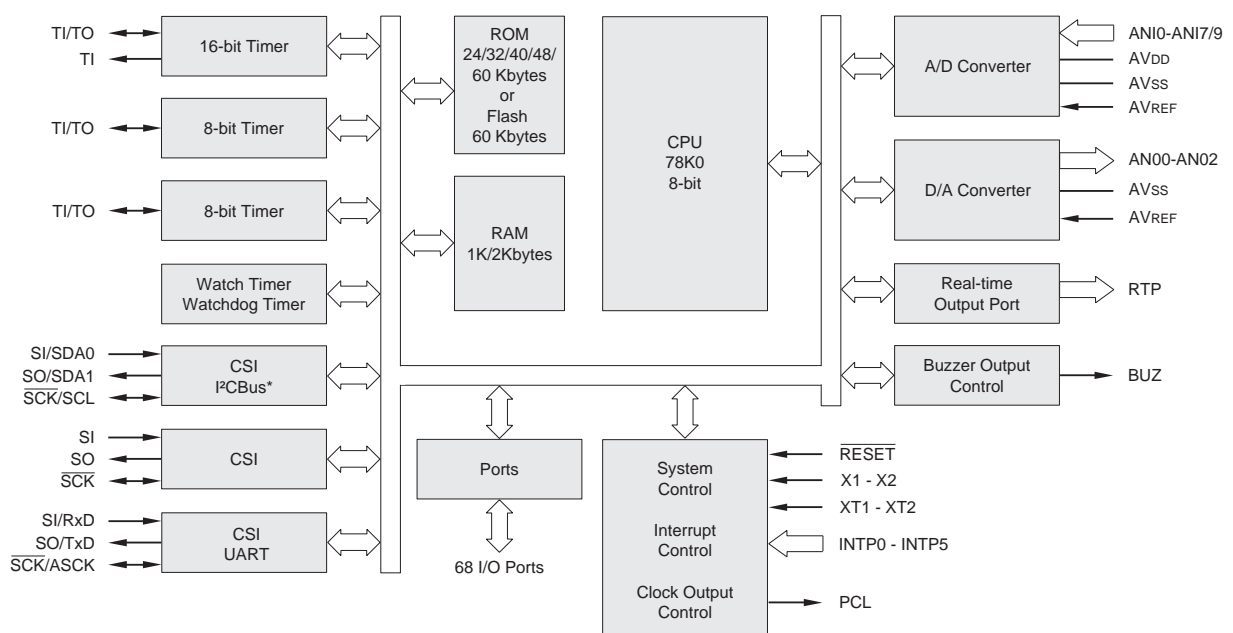

Functional Block Description

CPU	The core of the 78K0 family is a powerful 8-bit CPU. The 0.35 μm process technology ensures a good power/performance ratio for the $\mu\text{PD78005x}$. The CPU executes a set of 63 optimised instructions including fast multiply and divide instructions.
Memory	$\mu\text{PD78005x}$ devices offer a rich choice of on-chip memory combinations, including Mask ROM and Flash versions (see table). Flash memory can be written even with the device mounted in the target system.
Ports	The $\mu\text{PD78005x}$ devices have 10 ports with a total of 68 input/output pins. 62 CMOS input/output pins feature internal pull-up resistors, which can be enabled via software when the port is used for input. Two are CMOS input pins and four are N-channel open-drain I/O pins. 12 I/O pins are capable of directly driving LED's.
Real-time Output Port	Triggered by external hardware the real-time output port transfers data from a register to the output latch. The signal is free of jitter and therefore suitable for controlling stepper motors, etc.
A/D Converter	An 8-channel A/D converter with 8-bit resolution is provided on chip. An external analog value, within the supply voltage range, can be converted by successive approximation into an 8-bit digital value.
D/A Converter	A 2-channel D/A converter with 8-bit resolution is provided on chip. Using the R-2R resistor ladder method, an 8-bit digital input is converted to an analog voltage. In normal mode, the analog value is placed on the output immediately after the D/A conversion. In real-time output mode, the analog output is synchronised with the output trigger after D/A conversion.
Serial Interface	$\mu\text{PD78005x}$ devices have three serial interfaces channels that can be operated in different transfer modes. All three channels support 3-wire serial I/O, with channel 1 enhanced by an automatic transmission/reception function. Channel 2 can be operated in the UART mode incorporating a dedicated baud rate generator. The $\mu\text{PD78005xY}$ and $\mu\text{PD78F0058Y}$ controllers have a multimaster I ² C bus mode, all other devices feature the SBI (serial bus interface) mode.
Timer	All devices have 5 timer channels. One 16-bit timer is available for basic interval timing, as a PWM peripheral or to generate programmable square waves. The two 8-bit timers have a similar functionality and can also be used as external event counters. The watch timer can operate simultaneously as timing monitor and interval timer. The on-chip watchdog timer monitors CPU operation.
Clock Generator	The on-chip clock generator provides an operating frequency of 5 MHz. An external 32.768 kHz crystal can be connected to the XT1/XT2 terminal pair to generate the subclock frequency. Power consumption is significantly reduced in subclock mode.
Interrupt Controller	The interrupt controller handles three different types of interrupt requests issued by 20 sources. The watchdog timer is the only source to trigger a non-maskable interrupt. 6 external and 13 internal sources trigger maskable interrupts, with a priority of 0 to 17. The software interrupt is triggered by executing a BRK instruction.

Ordering Information

Devices

Part Number	ROM (Kbytes)	Flash (Kbytes)	RAM (Kbytes)
μPD780053	24	—	1
μPD780054	32	—	1
μPD780055	40	—	1
μPD780056	48	—	1
μPD780058	60	—	2
μPD78F0058	—	60	2

Note: Device orders must specify the package code GC (80-pin QFP), GK (80-pin TQFP). All devices are also available with I²C bus.

Documentation

Doc Number	Devices	Type
U11933EE3V0CD00	NEC Microcontrollers	CD-ROM
U12326EJ3V0UM00	78K0	Instruction Manual
U12013EJ2V0UM00*	μPD78005x	User's Manual
U12182EJ1V0PM00*	μPD780053/4/5/6	Data Sheet
U12328EJ1V0PM00*	μPD780053Y/4Y/5Y/6Y/8Y	Data Sheet
U12092EJ1V0PM00*	μPD78F0058	Data Sheet
U12324EJ1V0PM00*	μPD78F0058Y	Data Sheet

* Preliminary document

Tools

Order Number	Devices	Description	Type
DSWIN-I3HD-780xx	78K0	Simulator	Software
EB-78K0STARTER2	78K0	Starter Kit	Software & Hardware
78K0-TOOLSET	78K0	Tool Kit*	Software & Hardware
IE-780308-R-EM	μPD78(F)005x	Emulation Board	Hardware
EP-78230GC-R	μPD78(F)005xGC	Emulation Probe	Hardware
EP-78054GK-R	μPD78(F)005xGK	Emulation Probe	Hardware
EV-9200GC-80	μPD78(F)005xGC	LCC Socket	Hardware
TGK-80SDW	μPD78(F)005xGK	LCC Socket	Hardware
PG-FLASHPRO	78K Flash devices	Flash Programmer	Hardware
FA-80GC	μPD78F0058GC	Programming Adapter	Hardware
FA-80GK	μPD78F0058GK	Programming Adapter	Hardware

* Tool Kit includes C Compiler, Assembler, Debugger and In-circuit Emulator.

For further information on NEC's 78K0 Series or other NEC products visit our European website at www.nec.de

NEC Offices

NEC Electronics (Europe) GmbH, Oberrather Str. 4, D-40472 Düsseldorf,
Tel. (02 11) 65 03 01, Fax (02 11) 65 03-3 27

NEC Electronics (Germany) GmbH, Kanzlerstr. 2, D-40472 Düsseldorf,
Tel. (02 11) 65 03 02, Fax (02 11) 65 03-4 90
- Königstr. 12, D-30175 Hannover, Tel. (05 11) 3 34 02-0, Fax (05 11) 3 34 02-34
- Arabellastr. 17, D-81925 München, Tel. (0 89) 92 10 03-0, Fax (0 89) 91 31 82
- Industriestr. 3, D-70565 Stuttgart, Tel. (07 11) 9 90 10-0, Fax (07 11) 9 90 10-19

NEC Electronics (BNL) - Boschdijk 187a, NL-5612 HB Eindhoven,
Tel. (0 40) 2 44 58 45, Fax (0 40) 2 44 45 80

NEC Electronics (Scandinavia) - Täby Centrum, Entrance S (7th floor),
S-18322 Täby, Tel. (08) 6 38 08 20, Fax (08) 6 38 03 88

NEC Electronics (France) S.A., 9, rue Paul Dautier, B.P. 187,
F-78142 Velizy-Villacoublay Cédex, Tél. (01) 30 67 58 00, Fax (01) 30 67 58 99

NEC Electronics (France) S.A., Representacion en Espana,
Juan Esplandiu 15, E-28007 Madrid, Tel. (01) 5 04 27 87, Fax (01) 5 04 28 60

NEC Electronics Italiana S.R.L., Via Fabio Filzi, 25A, I-20124 Milano,
Tel. (02) 66 75 41, Fax (02) 66 75 42 99
- Rome Office, Via Monte Cervialto, 131, I-00139 Roma,
Tel. (06) 8 86 22 91/2, Fax (06) 8 86 22 39

NEC Electronics (UK) Ltd., Cygnus House, Sunrise Parkway, Milton Keynes,
GB-MK14 6NP, Tel. (0 19 08) 69 11 33, Fax (0 19 08) 67 02 90
- Scotland Office, Block 3, Carfin Industrial Estate, Motherwell GB-ML1 4UL,
Tel. (0 16 98) 73 22 21, Fax (0 16 98) 83 38 68

© Published by NEC Electronics (Europe) GmbH, Printed in Germany, May 1998
Document No. U13507EE1V0PL00

With compliments

NEC makes no warranty with respect to this documentation and disclaims any implied warranties of merchantability or fitness for particular purpose. NEC does not assume any responsibility for circuits shown or claim that they are free from patent infringement. Product specifications are subject to change without notice. To ensure that you have the latest product data, please contact your local NEC sales office.

© NEC Electronics (Europe) GmbH